

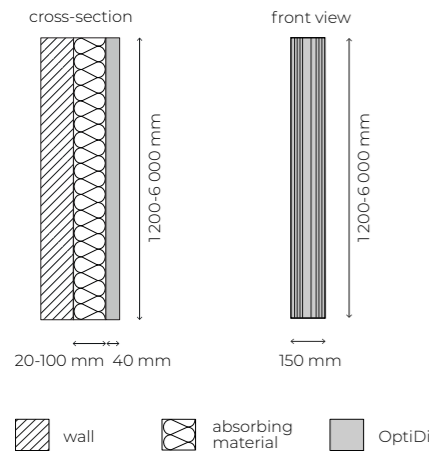

# OPTIDI



OptiDi, whilst giving your interior a unique aesthetics, it combines philosophy of minimalistic design and great acoustic properties. Its specific shape made of aluminium provides sound diffusion combined with efficient absorption in a lower frequency range. OptiDi is one of the kind diffuser providing a great visual effect and outstanding acoustical performance.



## pattern version

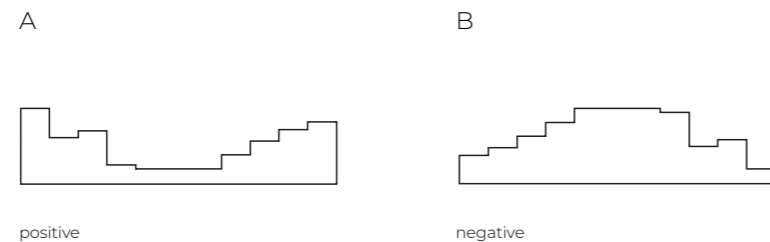

**Size**  
150 x 1200 x 40 mm  
(max length: 7.30 m)

**Weight**  
17 kg/m<sup>2</sup>

**Material**  
aluminium

Possible finish in any colour from the RAL palette or wood-like varnish.

## RAL



## varnish

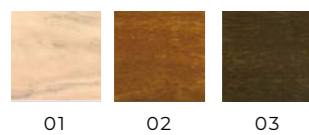

**Designer**  
Architected Sound Team

**Country of production**  
Poland

**Category**  
diffusion / absorption

**Description**  
OptiDi system diffuses sound in mid and high frequencies, most effectively as a combination of positive and negative modules. Thanks to the sound-absorbing material (installation behind the OptiDi elements, the thickness and density of the sound-absorbing material designed for a specific case) and the variable width of the gaps between the individual elements, the absorption in the bass range can be tuned to the required frequencies.

**Sound absorption coefficient**  
 $\alpha_{w, \max} = 0.20$

**Fire safety**  
Made of materials with flammability class A1.

**Application**  
Concert and philharmonic halls, theatres, opera houses, rehearsal rooms, recording studios, control rooms, radio and TV emission rooms, conference rooms, lecture rooms and classrooms, waiting rooms, offices, dedicated listening rooms.

**Custom-made**  
Usually custom-made due to specific absorption needed. Ceiling structure and mobile version possible.

**Installation**  
Necessity of assembly on a substructure (plywood grid, galvanized consoles + aluminum grid). It is essential that the OptiDi support substructure rests on the floor.

## Architected Sound OptiDi – sound absorption and scattering coefficients

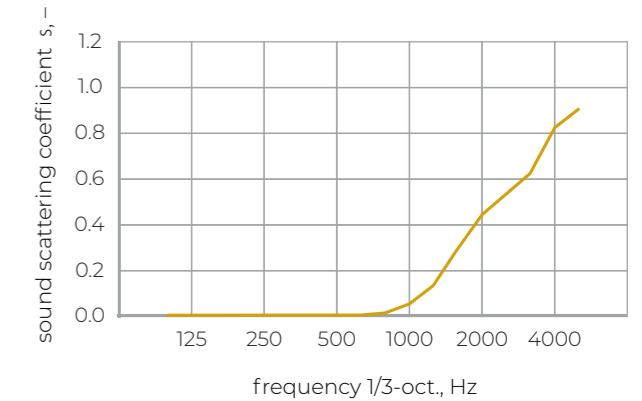
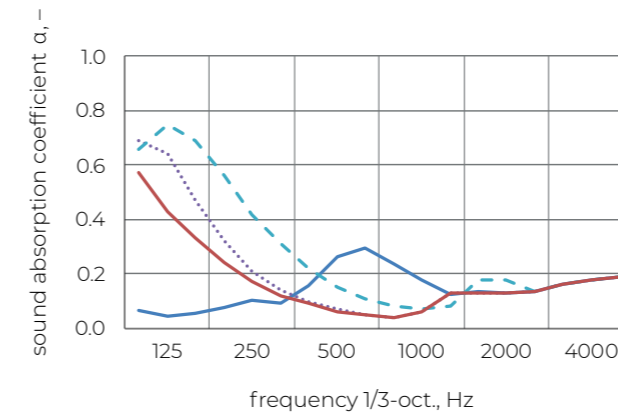

## Practical sound absorption coefficient $\alpha_p$

mounting type	A-40	C-50	C-60	C-100
frequency 1/1 oct.	—	.....	- - - - -	—
125 Hz	0.05	0.60	0.70	0.45
250 Hz	0.10	0.20	0.45	0.20
500 Hz	0.25	0.05	0.15	0.05
1000 Hz	0.20	0.10	0.10	0.10
2000 Hz	0.15	0.15	0.15	0.15
4000 Hz	0.20	0.20	0.20	0.20

## Sound scattering coefficient $s$

frequency 1/3-oct.	$s$
1000 Hz	0.05
1250 Hz	0.13
1600 Hz	0.28
2000 Hz	0.44
2500 Hz	0.53
3150 Hz	0.62
4000 Hz	0.82
5000 Hz	0.90

- A-40: direct mounting, o.d.s. 40 mm \*
- ..... C-50: slit 1 mm + mineral wool 50 mm (35 kg/cbm), o.d.s. 90 mm \*
- - - - - C-60: slit 3 mm + mineral wool 60 mm (35 kg/cbm), o.d.s. 100 mm \*
- C-100: slit 1 mm + mineral wool 100 mm (35 kg/cbm), o.d.s. 140 mm \*

\* results obtained from analytical calculations  
\*\* measurements conducted in accordance to ISO 17497-1:2004



## Additional information

Technical solution developed in cooperation with the AGH University of Science and Technology in Krakow. Community design number: 004417723-0001 and 004417723-0002.



# OPTIDI



diffusion



absorption



low tones

OptiDi, whilst giving your interior a unique aesthetics, it combines philosophy of minimalistic design and great acoustic properties. Its specific shape made of aluminium provides sound diffusion combined with efficient absorption in a lower frequency range. OptiDi is one of the kind diffuser providing a great visual effect and outstanding acoustical performance.

## OptiDi assembly

Installation of the OptiDi acoustic diffuser in accordance with the instructions available on the website <https://www.architected-sound.com/en/products/optidi/#downloads>.

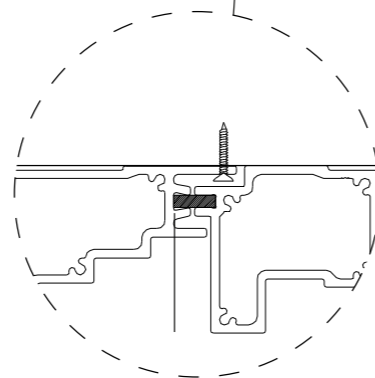
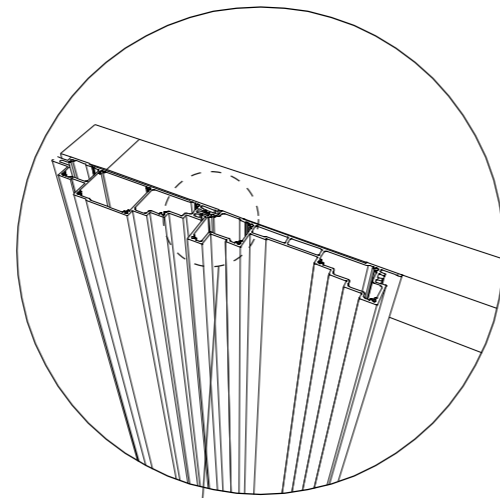
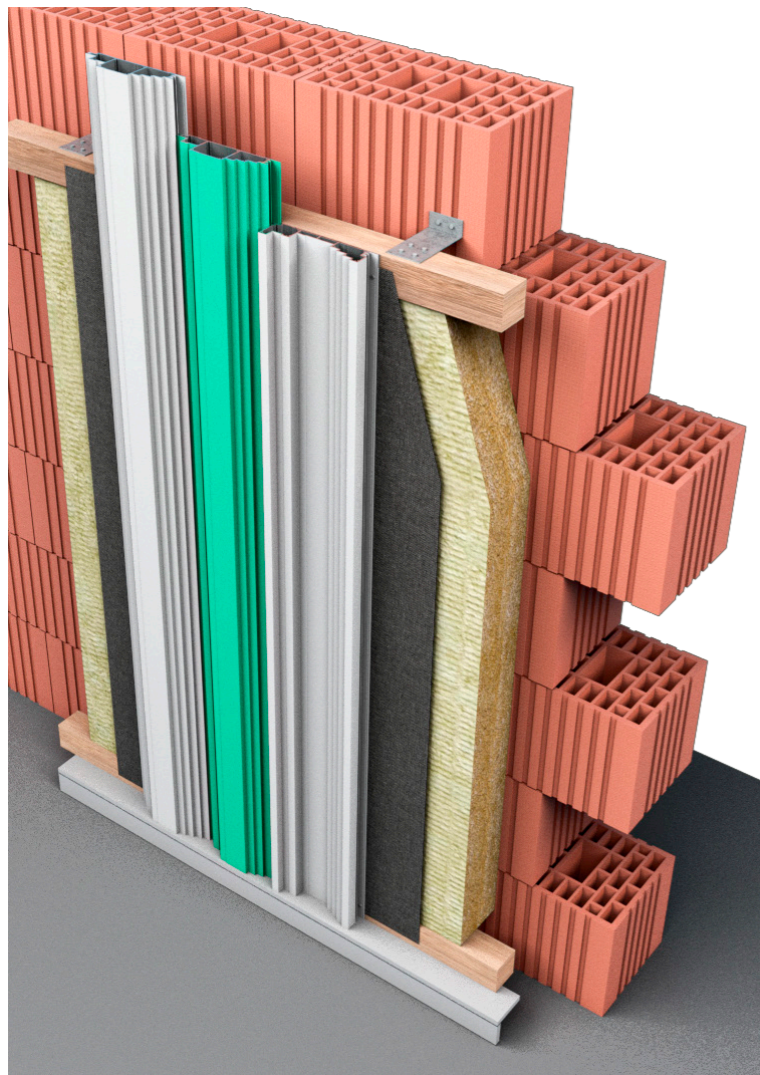

OptiDi should be screwed to the substructure with screws to adjust the width of the gap (a slit) using distance blocks provided as part of the order.

In order to achieve low-tone absorption, the space between the substructure elements is filled with a sound-absorbing material with a selected density (for example: rock wool).

OptiDi can be combined with the modular SlotBar absorbing structure.

