

# UP-SORBER ROLL





UP-SORBER ROLL is an electrically adjustable banner that can change room's acoustic conditions in the blink of an eye. Customizing the space function has never been so quick and convenient.





UP-SORBER ROLL banners  
can be ordered  
in individually selected  
sizes and colours,  
which allows you to design  
the interior with an original  
visual form and excellent  
acoustic properties.





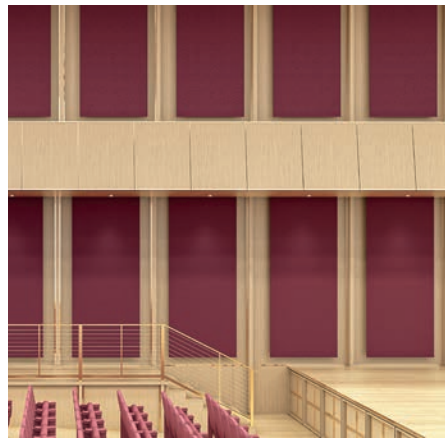

# UP-SORBER ROLL



absorption



mid tones



high tones

Up-Sorber Roll was created to meet the requirements of adjusting the acoustics in multifunctional spaces. This purpose was achieved by designing the fabric surface rolled up or down to any length required to fit particular environment. Thanks to dedicated control system, setting proper acoustics has never been easier.

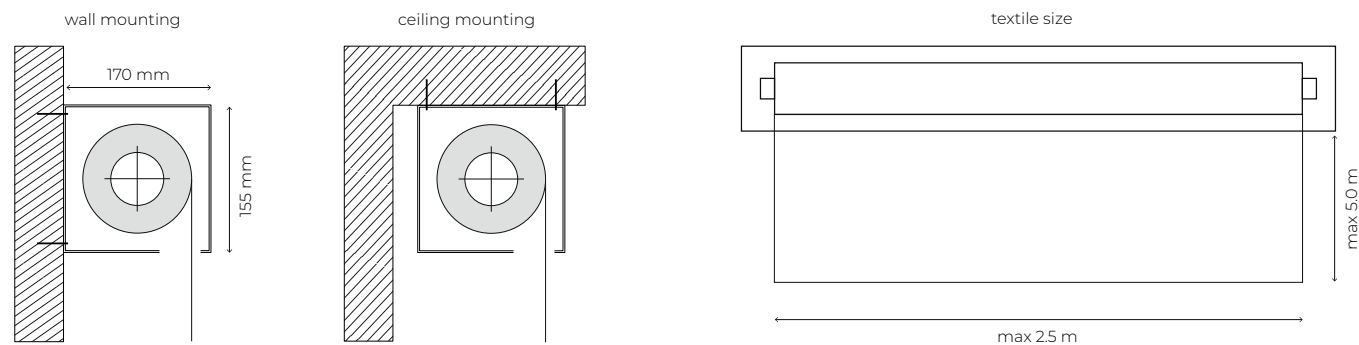

## Size

width: standard 1.4 m,  
max 2.5 m  
length: max 5.0 m

## Weight

ca. 26 kg

## Material

absorptive fabrics

Available in various sizes and colours according to individual project.



## Designer

Architected Sound Team

## Country of production

Poland

## Category

absorption

## Description

Up-Sorber Roll contains an expandable surface made of textile materials, ensuring the regulation of reverberation time in the range of medium and high tones by increasing the acoustic absorption of the interior and eliminating the first reflections of the sound.

Up-Sorber Roll can be made of one or two layers of textile. The latter increases acoustic absorption in low frequencies and allows obtaining maximum uniformity of acoustic conditions in the whole room.

The system is designed to be installed on walls or ceilings. Specialized mounting procedure required due to individual character of each project.

## Sound absorption coefficient

$\alpha_{w, \max} = 0.65$

## Application

Multifunctional rooms, concert halls, theaters, lecture and conference rooms, home listening rooms, rooms in buildings under the supervision of the conservator.

## Control

The electric drive is equipped with adjustable limit switches. Wired or radio control, with the ability to group more banners. Possibility of integration with external control systems.

Drive parameters:  
power supply: 230 V  
power consumption during operation: max 200 W

## Custom-made

Non-standard length and width possible. Possibility of creating a passive surface that can be made of materials ensuring free air flow, such as steel cables or mesh.

## Fire safety

Made of materials with flammability class B-s2, d0.

## Architected Sound Up-Sorber Roll – sound absorption coefficients

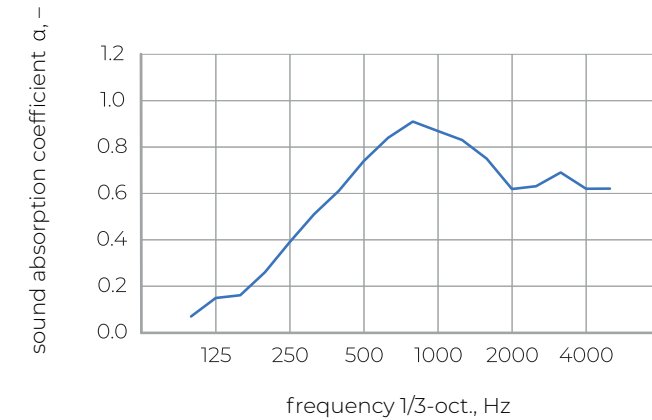

## Practical sound absorption coefficient $\alpha_p$

frequency 1/1-oct.	$\alpha_p$
125 Hz	0.15
250 Hz	0.40
500 Hz	0.75
1000 Hz	0.85
2000 Hz	0.65
4000 Hz	0.65

— distance of the expanded surface from the wall: 100 mm



Expanded UP-SORBER ROLL banners reduce the reverberation time of the interior and increase its acoustic absorption, preventing the first reflection of sound waves generated, for example, by loudspeakers. Rolled up they are invisible and do not interfere with the interior design.



